

RTD ASSEMBLIES

HEAD TYPE

Screw Cover Heads

Model No. **R10** — Cast Aluminum Head

Model No. **R11** — Cast Iron Head

Model No. **R12** — Plastic Head

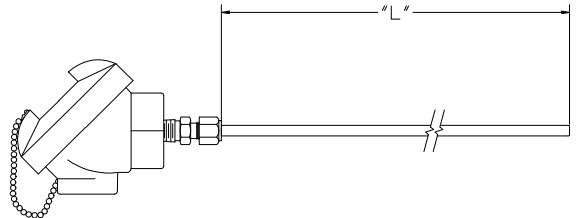

Flip-Top Heads

Model No. **R13** — Cast Aluminum Head

Model No. **R14** — Plastic Head (FDA Approved)

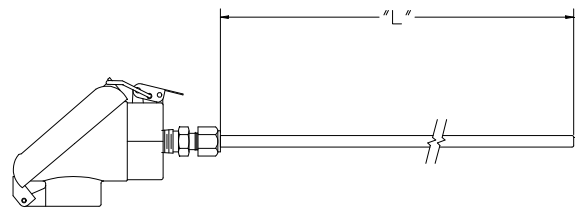

Explosion Proof Heads

Model No. **R15** — Cast Aluminum

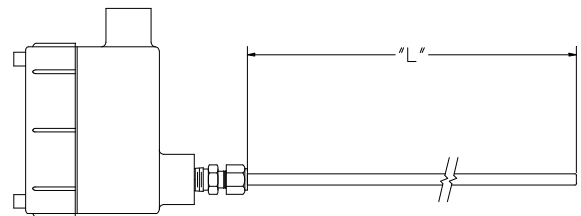

Mini Heads

Model No. **R16** — Bayonet Lock Aluminum
(4 Wire Maximum)

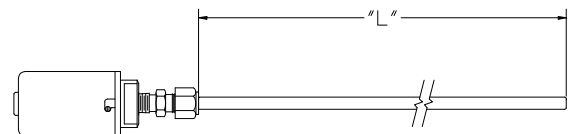

Open Heads

Model No. **R17** — Exposed Terminal Thermo-Plastic
(4 Wire Maximum)

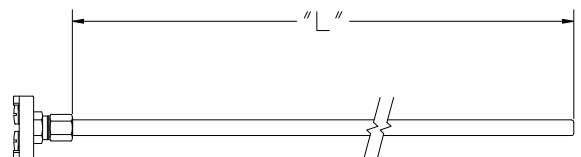

RTD TYPE PART NUMBER SELECTION TABLES

HEAD TYPE

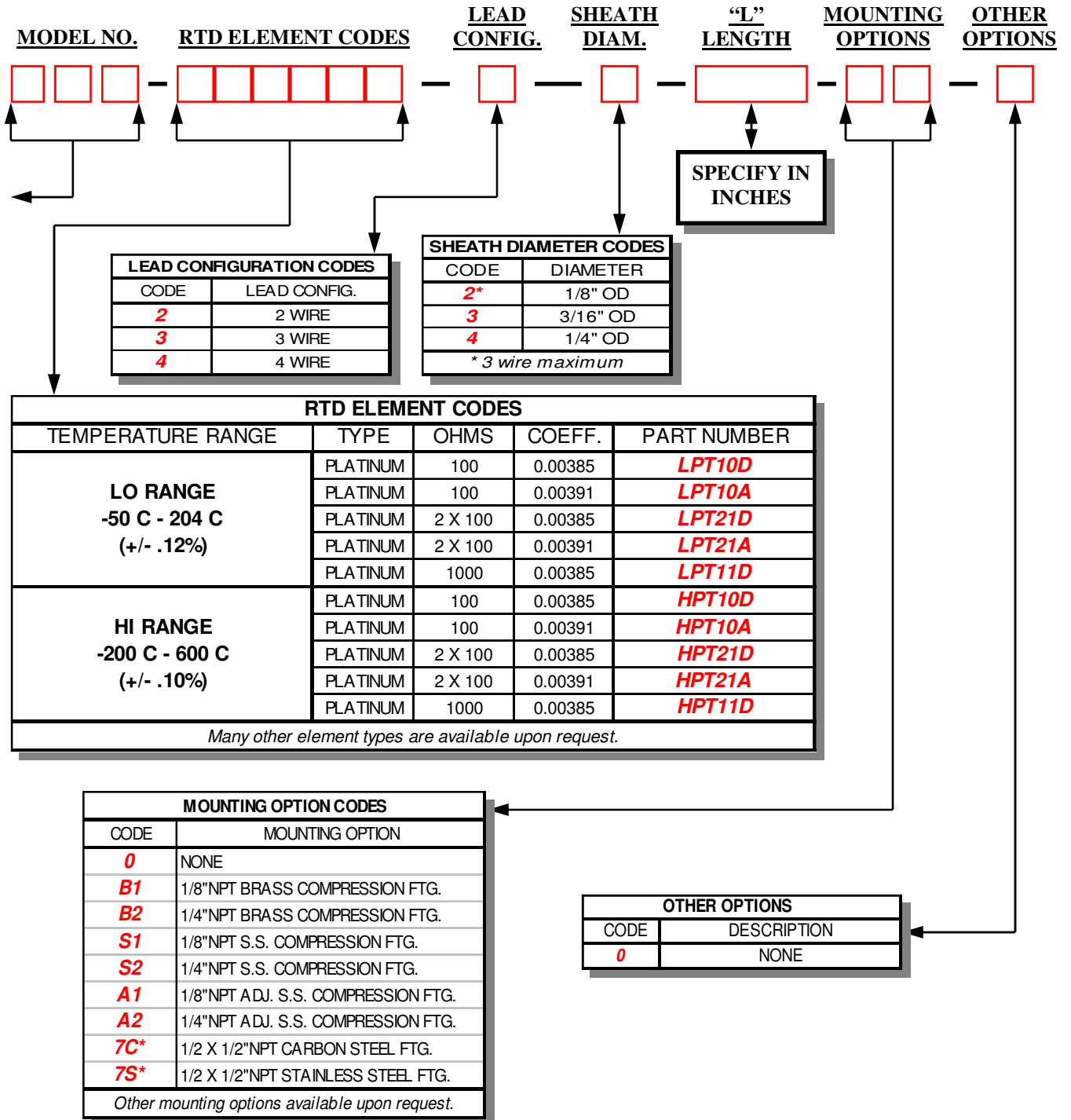

* Not available on models # R16 & # R17